

ABSTRACT

The three main objectives that a suspension system of an automobile must satisfy are ride comfort, vehicle handling and suspension working space. Ride comfort is directly related to the vehicle acceleration experienced by the driver and the passengers. Lesser vertical acceleration, higher is the level of comfort. The aim of the Project was to design and analyze the semi active suspension system models using skyhook, ground hook and hybrid control for quarter car. The project work includes modeling of semi-active suspension system in MATLAB simulink, using 2 degree of freedom quarter car model. The skyhook on-off, ground hook and hybrid control strategies were designed using control laws stated in literatures. Simulated results have been compared with passive system for time response analysis of body vertical displacement and vertical displacement of quarter car. Simulation was carried out for various road conditions such as random road excitation, road bump excitation, step input etc.

The simulated results for quarter car model are shows similar trends and within range when compared with reference research paper.

KEYWORDS: Vehicle Suspension System, Skyhook control, Ground Hook, Hybrid Control Strategies.

INTRODUCTION

With the increasing competition in automotive sector, the customer is available with more options when it comes to buying a vehicle. So it has become necessary to improve the vehicle's characteristics which affect its impression on the customer. At the same time, keeping the vehicle development cycle to minimum possible time has become essential. Many new techniques are coming to reduce the vehicle development cycle which allows the company to keep up with the current market demand. Handling and ride comfort are very important characteristics that influence the quality of the vehicle. These characteristics depend on the suspension system of the vehicle.

These advanced suspensions are basically required to provide a high level of ride comfort while maintaining a reasonable ability to ensuring safety by keeping the vehicle on the road. Passive suspension components are still very competitive, because they are simple, reliable, and inexpensive and do not need a power supply, but the performance from the viewpoint of ride comfort is much worse when compared with the active and semi active systems.

LITERATURE REVIEW

Usual suspension systems of vehicles are passive suspensions. In these systems, the characteristics of the suspension elements are constant. In the design of these systems, there is an inherent compromise between good ride comfort and vehicle stability as the two main goals of the design. A vehicle suspension with stiff spring and firm damper is referred as 'hard' suspension. This provides good control on the vehicle body motion and wheels vibration, and it creates optimal handling. However, this system is unable to offer effective body isolation. On the other hand, a suspension with low stiffness and soft damping, called 'soft' suspension provides effective body isolation from road unevenness and creates good ride comfort. However, this system cannot control the motions of the vehicle body and wheels effectively. Therefore, in the design of conventional passive suspensions, a

compromise has to be made between good handling and ride comfort. A passive suspension does not offer a compromise solution between ride comfort and vehicle handling. It either offers a good comfort and compromised handling or vice versa. For this reason people began to explore other options such as active and semi-active suspension which would provide good compromise between the conflicting requirements.

To achieve good vibration isolation for the sprung mass over a wide range of frequency, a soft suspension spring is generally required, while to provide good road holding capability at a frequency close to the natural frequency of the unsprung mass ("wheel hop" frequency), a stiff suspension spring is preferred. To reduce the amplitude of vibration of the sprung mass at a frequency close to its natural frequency, a high damping ratio is required, while in the high-frequency range, to provide good vibration isolation for the sprung mass, a low damping ratio is preferred. On the other hand, to achieve good road holding capability in the high- frequency range, a high damping ratio is required. These conflicting requirements cannot be met by a conventional (passive) suspension system since the characteristics of its spring and shock absorber are fixed and cannot be modulated in accordance with the operating conditions of the vehicle.

To provide the vehicle with improved ride quality, handling, and performance under various operating conditions, the concept of an active suspension has emerged, and various active systems have been proposed or developed. The spring and shock absorber in a conventional system are replaced by a force actuator in an active system. The actuator may also be installed in parallel with a conventional suspension spring. The operating conditions of the vehicle are continuously monitored by sensors. Based on the signals obtained by the sensors and the prescribed control strategy, the force in the actuator is modulated to achieve improved ride, handling, and performance. The optimum control strategy is defined as the one that minimizes the value of the sprung mass acceleration, the body vertical displacement & wheel vertical displacement. Usually, these quantities are multiplied by weighting factors, and then combined to form an evaluation function. Various control theories have been applied to establishing the optimum control strategy to minimize the evaluation function.

An active suspension requires significant external power to function and that there is also in considerable penalty in complexity, reliability, cost and weight. With a view to reducing complexity and cost while improving ride, handling, and performance, the concept of a semi-active suspension has emerged. In this kind of system, the conventional suspension spring is usually retained, while the damping force in the shock absorber can be modulated in accordance with operating conditions. The concept of semi- active suspension system is illustrated in following figure.

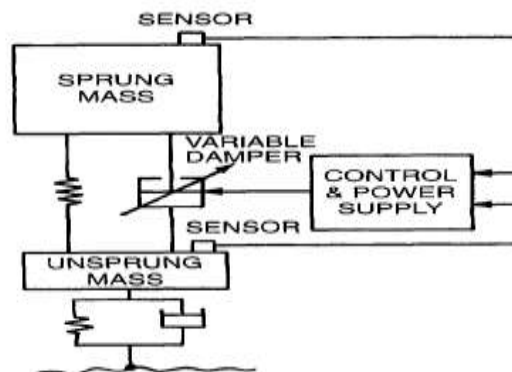

Fig 1:- Semi active Suspension System

Daniel S. Motta and et al from State University of Campinas [1] compared optimized passive system, a semi-active on-off system and a semi-active CVD (continuously variable Damper) system in relation to ride comfort and tire deflection. A semi-active damping system is basically a dissipative element in which the dissipation law can be actively modulated. They simulated the system based on a quarter car model and the control laws of the semi-active system were based on 'sky hook' theory, where damping coefficient are switched depending on the sign of the product of body velocity and damper velocity. The semi-active control law of continuously variable damper (CVD) is proposed to follow the behavior of an ideal skyhook damping. It means that the damper force in the semi-active case must be equal to the damper force in the skyhook case.

Numerical results were evaluated in terms of vertical displacement, body vertical acceleration and the tire deflection. The excitation used was a step of 5 cm, after 0.5 seconds. From body displacement graph, passive system presented a low damping, as consequence a high overshoot in the beginning of the oscillation. On the other hand, the overshoot in the 'on-off' system was also eliminated semi-active 'CVD' system can be applied with better ride comfort compared to the passive and semi-active 'on-off' system without the penalty of lower safety. D. Moline and et al from Clemson University [2] developed a simulation of the vehicle response of a nonlinear 1/4 car model consisting of a sprung and unsprung mass. It is being used for preliminary evaluation of various suspension configuration & control algorithms. Non-linearity's include hysteretic shock damping & switchable damping characteristics. Road inputs include discrete events such as bumps & potholes as well as randomly irregular roads.

MATHEMATICAL MODELLING OF A PASSIVE SUSPENSION SYSTEM

This section includes simplest representation of a vehicle suspension. It consists of Two-degree of freedom that represents 1/4th of the vehicle sprung mass, one spring and a damper in parallel, 1/4th unsprung mass and the tyre stiffness. The value of the damping co-efficient is fixed in this case (passive damping). The following figure shows the quarter car suspension model in general, whereas passive damper can be replaced with semi-active damper.

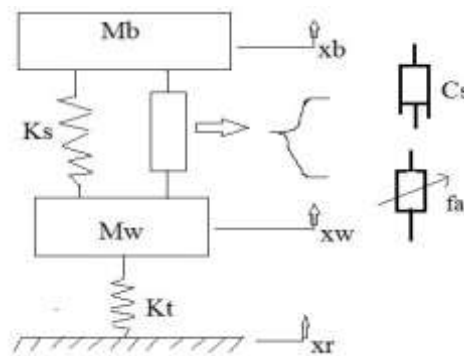

Fig 2:- Passive Suspension System

By applying Newton's second law to the quarter car vehicle model, the equation of motion of sprung mass and un sprung mass are

$$M_b \ddot{x}_b + K_s(x_b - x_w) + f = 0 \quad (1)$$

$$M_w \ddot{x}_w - K_s(x_b - x_w) + K_t(x_w - x_r) - f = 0 \quad (2)$$

Where, the force from the damping device is given by;

$$f = C_s(\dot{x}_b - \dot{x}_w), \quad \text{for passive suspension}$$

$$f = f_a, \quad \text{for semi-active suspension}$$

Where C_s being the coefficient for the passive suspensions damper. Here, we have neglected the tyre's coefficient of damping.

The model parameters sets considered are of quarter car ,represents a classical parameter set for automotive applications. These parameter sets are of passenger car's front left side which are used for model design, simulation and analysis of a quarter car model [5].

Sr.no	Parameter	Numerical Value(unit)
1	Sprung mass(M_b)	365 (kg)
2	Un sprung mass(M_w)	40 (Kg)
3	Suspension stiffness(K_s)	19960 (N/m)
4	Tire stiffness(K_t)	175500 (N/m)
5	Damping coefficient(C_s)	1290 (Ns/m)

SKYHOOK CONTROL

The skyhook damper configuration attempts to eliminate the trade-off between resonance control and high frequency isolation common to passive suspensions. The damper is connected to an inertial reference in the sky.

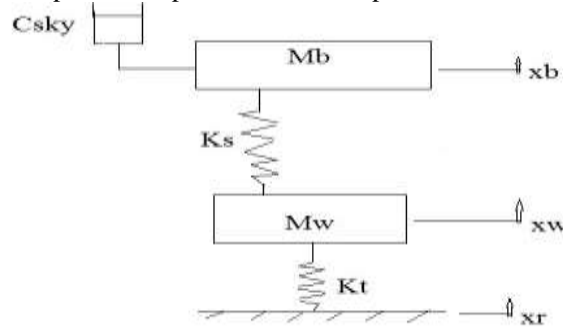

Fig 3:- Skyhook Damper Configuration

Another approach to achieving skyhook damping is to use semi active dampers. Semi active dampers allow for the damping coefficient, and therefore the damping force, to be varied between high and low levels of damping. Early semi active dampers were mechanically adjustable by opening or closing a bypass valve. A magneto-rheological damper which varies the damping by electrically changing the magnetic field applied to the magneto-rheological fluid is used [12].

Once it is decided that a semi-active damper will be used, the means of modulating the damper such that it simulates a skyhook damper must be determined the velocity of the sprung mass relative to the unsprung mass Mb , to be positive when the sprung mass and unsprung mass are separating (i.e. when $\dot{x}b$ is greater than $\dot{M}w$) for the systems shown in Figure 4. Assuming that for both systems, the sprung mass is moving upwards with a positive velocity $\dot{x}b$

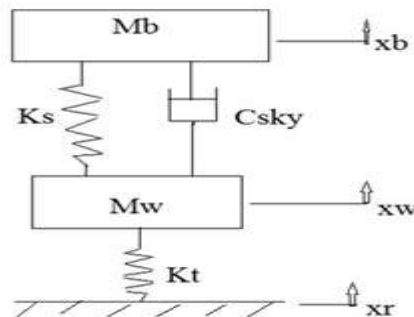

Figure 4. Practical implementation of Skyhook Damper Configuration

If we consider the force that is applied by the skyhook damper to the sprung mass,

$$Fsky = Csky * \dot{x}b \tag{3}$$

Where, $Fsky$ is skyhook force Next is to determine if the semi-active damper is able to provide the same force. If the sprung and unsprung masses are separating, then the semi-active damper is in tension. Thus, the force applied to the Sprung mass is;

$$fa = Csa(\dot{x}b - \dot{x}w) \tag{4}$$

Where, fsa is the force applied to the sprung mass. Since we are able to generate a force in the proper direction, the only requirement to match the skyhook suspension is,

$$Csa = Csky \dot{x}b / (\dot{x}b - \dot{x}w) \tag{5}$$

Now consider the case in which the sprung and unsprung masses are still separating, but the sprung mass is moving downwards with a negative velocity $\dot{x}b$. In the skyhook configuration, the damping force will now be applied in the upwards, or positive direction. In the semi-active configuration, however, the semi-active damper is still in

tension, and the damping force will still be applied in the downwards, or negative, direction. Since the semi-active damping force cannot possibly be applied in the same direction as the skyhook damping force, the best that can be achieved is to minimize the damping force. However, a damper generates the damper force always in the inverse direction of suspension movement.

The on-off skyhook control strategy switches between high and low damping coefficient in order to achieve body comfort specifications. This control law consists in changing the damping factor of the damper (its fluid viscosity, air resistance, etc) according to the body velocity and the suspension relative velocity by using a logical rule as [12]:

$$C_{sa} = \begin{cases} C_{max}, & \text{If } \dot{x}_b * (\dot{x}_b - \dot{x}_w) \geq 0 \\ C_{min}, & \text{else } \dot{x}_b * (\dot{x}_b - \dot{x}_w) < 0 \end{cases} \quad (6)$$

It is worth emphasizing that when the product of the two velocities is positive that the semi-active damping force is proportional to the velocity of the sprung mass. Otherwise, the semi-active damping force is at a minimum. Where, C_{max} and C_{min} are the maximum and minimum damping coefficients of damper, respectively (and usually $C_{max} = C_{sky}$). Equation (4.4) implies that when the relative velocity across the suspension and the sprung mass absolute velocity have the same sign, a damping force proportional to C_{max} is desired. Otherwise, this control law deactivates the controlled damper when the body velocity and relative velocity have opposite sign.

For semi-active simulation, choosing maximum and minimum coefficient of damping value also play an important role for designing each semi-active suspension control strategies. Semi-active damping coefficients are chosen using two relationships as described by [5], $C_{max} = 2.2C_s$ and $C_{min} = 0.2C_s$.

Based on passive damping coefficient values for front and rear suspension (i.e. $C_s = 1290\text{Ns/m}$ and $C_s = 1620\text{Ns/m}$) respectively, $C_{max} = 2838\text{Ns/m}$ and $C_{min} = 258\text{Ns/m}$ for front suspension and $C_{max} = 3564$, $C_{min} = 324\text{Ns/m}$ for rear suspension of a car are considered for semi-active suspension simulation of a half car. The simulink model for an On-off skyhook controlled semi-active suspension for quarter car is shown below as

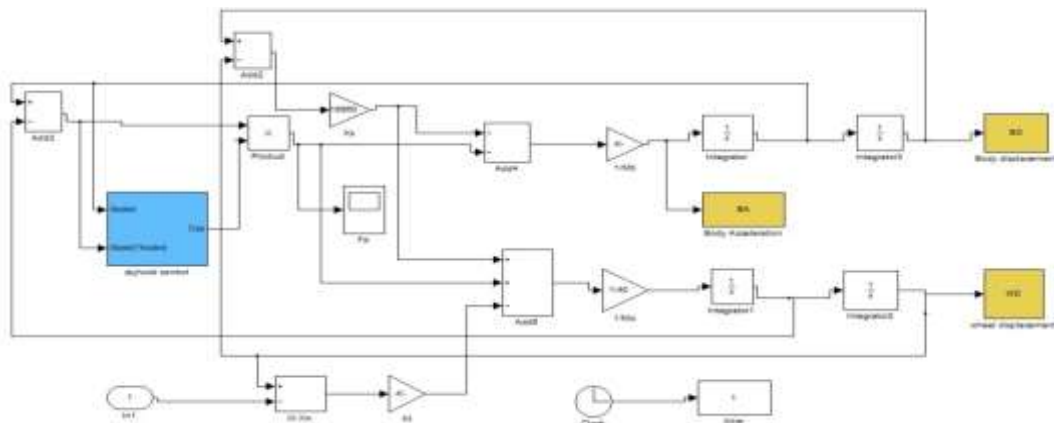

Figure 5. Simulink quarter car model for skyhook on-off semi-Active suspension.

In a semi-active suspension, dampers are able to generate force only in the opposite direction of the suspension, and the control strategy includes always a switching law in order to turn the damper off, as the damping force is in the inverse direction. Because of this switching, the damping forces are discontinuous in these systems.

GROUND-HOOK CONTROL

The ground hook control is modified from skyhook damper configuration so that the damper is connected to M_u (the unsprung mass) rather than M_s (the sprung mass) [10]. The resulting system is referred to as the ground hook damper configuration, and is shown in Figure.

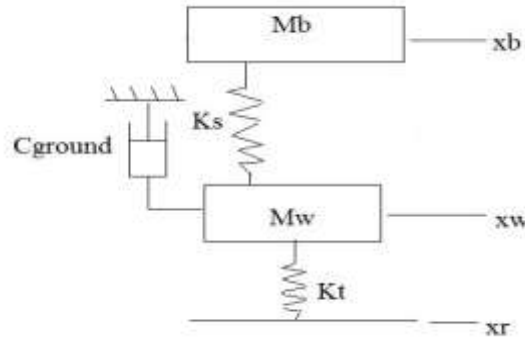

Figure 6. Ground hook damper configuration

The system response of the ground hook configuration is similar to the response of the skyhook configuration, with the obvious difference that the ground hook configuration effectively adds damping to the unsprung mass and removes it from the sprung mass. The logical rule is [12],

$$C_{sa} = \begin{cases} C_{max}, & \text{If } -\dot{x}_w(x_b - \dot{x}_w) \geq 0 \\ C_{min}, & \text{else } -\dot{x}_w(x_b - \dot{x}_w) < 0 \end{cases} \quad (7)$$

The ground hook control strategies can be developed as that of skyhook on-off control strategy. The simulink model for a groundhook controlled semi-active suspension for quarter car is shown below as;

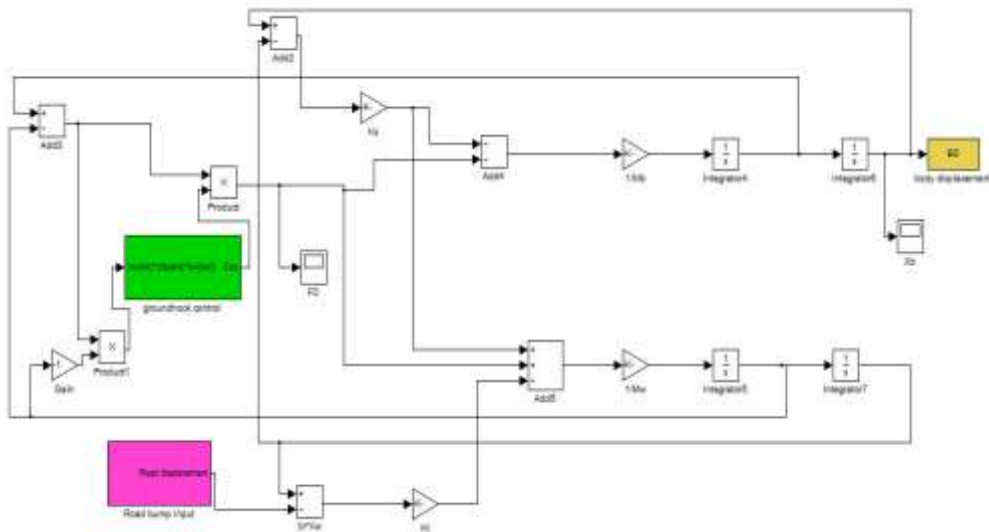

Figure 7:- Ground-hook controlled quarter car suspension Simulink model

HYBRID CONTROL

An alternative semi-active control policy known as hybrid control has been shown to take advantage of the benefits of both skyhook and ground hook control. With hybrid control, the user has the ability to specify how closely the controller emulates skyhook or ground hook. In other words, hybrid control can divert the damping energy to the bodies in a manner that eliminates the compromise that is inherent in passive dampers. The hybrid configuration is shown in Figure.

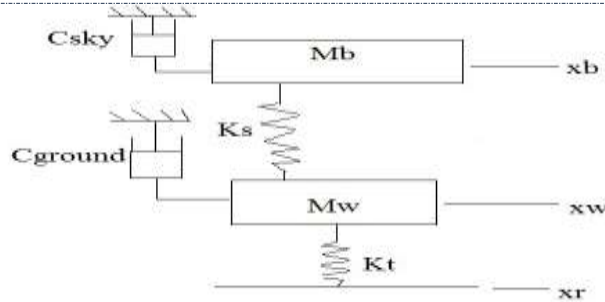

Figure 8. Hybrid control damper configuration

The hybrid control policy can be expressed as [8],

$$\begin{aligned} \dot{x}b(\dot{x}b - \dot{x}w) \geq 0 & \quad \sigma_{sky} = \dot{x}b \\ \dot{x}b(\dot{x}b - \dot{x}w) < 0 & \quad \sigma_{sky} = 0 \end{aligned} \tag{9}$$

$$\begin{aligned} -\dot{x}w(\dot{x}b - \dot{x}w) \geq 0 & \quad \sigma_{ground} = \dot{x}w \\ -(\dot{x}b - \dot{x}w) < 0 & \quad \sigma_{ground} = 0 \end{aligned} \tag{10}$$

$$f_{sa} = G[\alpha * \sigma_{sky} + (1 - \alpha)\sigma_{gnd}] \tag{11}$$

Where σ_{sky} and σ_{gnd} are skyhook and ground hook components of the damping force. The variable α is the relative ratio between the skyhook and ground hook control and G is constant gain. Where, G is the damping coefficients of the skyhook and ground hook dampers, which are assumed equivalent as:

$$C_{sky} = C_{ground} = G \tag{12}$$

The tendency of hybrid control method can be adjusted by changing the ratio α , which has value between zero to one. With value one hybrid completely converts to skyhook control whereas with value zero it converts to ground hook control strategy [5].

Indeed, this value defines the priority of the control design. For our design, we have chosen the value of α to be 0.9 as we intend to have more ride comfort in our suspension. Here, maximum damping coefficient value for front and rear suspension that we have used for skyhook and groundhook controls are 2838N/m and 3564N/m respectively. According to hybrid control law, damping coefficient for hybrid control can also be calculated with multiplying α value to skyhook gain and $(1 - \alpha)$ value to groundhook gain. Those values are respective maximum and minimum values of damping for hybrid control. Hybrid simulink model for a quarter car model is developed as below:

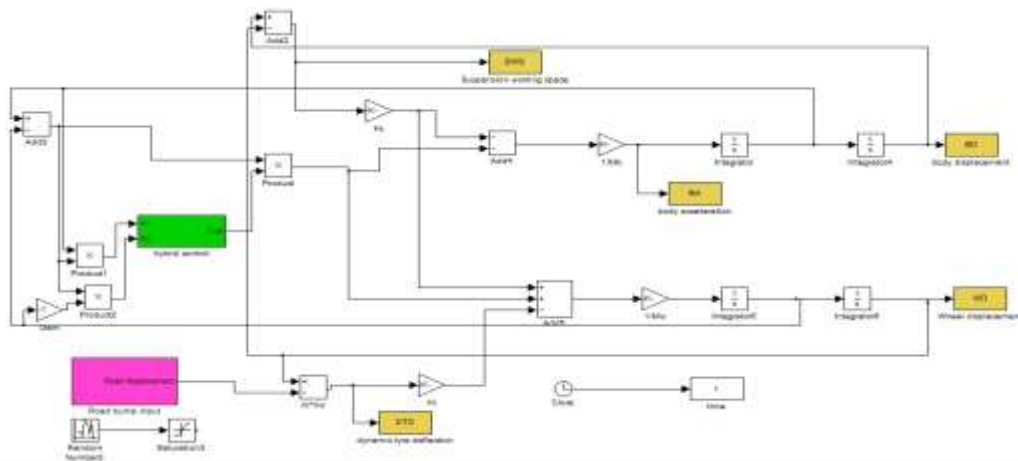

Figure 9. Hybrid controlled quarter car suspension Simulink model.

Absolute velocities of sprung mass and unsprung mass for each wheel and relative velocities are considered from equations (4.5 to 4.8). Based on these equations hybrid control strategy can be modelled in simulink.

SIMULATION RESULTS AND DISCUSSION

Two types of inputs chosen in this project for passive and semi- active suspension system model simulation are of road excitation, which are very similar to the real-world road profiles. These types of road excitation are chosen from literature.

THE ROAD BUMP EXCITATION

The speed bump Speeds of 5km per hour which passes over bump of height 100mm has been chosen for simulation. A signal generator emits a sine wave with amplitude of 100mm of frequency of 1.852Hz. Two step signals are then introduced. The first step signal is sent to correspond to the start of the positive side of the sign wave. The next step has an initial value equal to that the final value of the first step input.

RANDOM ROAD EXCITATION

W_n is white noise with intensity $2\sigma^2\rho V$. ρ is the road irregularity parameter and σ^2 is the covariance of road irregularity. In random road excitation, the values of road surface irregularity ($\rho = 0.45 \text{ m}^{-1}$ and $\sigma^2 = 300 \text{ mm}^2$) were selected assuming that the vehicle moves on the paved road with constant speed $V = 20 \text{ m/s}$.

The output of the random block is clipped by a saturation block which restricts the values of the road excitation between -0.05 m to 0.05 m i.e -50 mm to 50 mm .

SIMULATION RESULTS OF A QUARTER CAR MODEL FOR ROAD BUMP EXCITATION **BODY VERTICAL DISPLACEMENT**

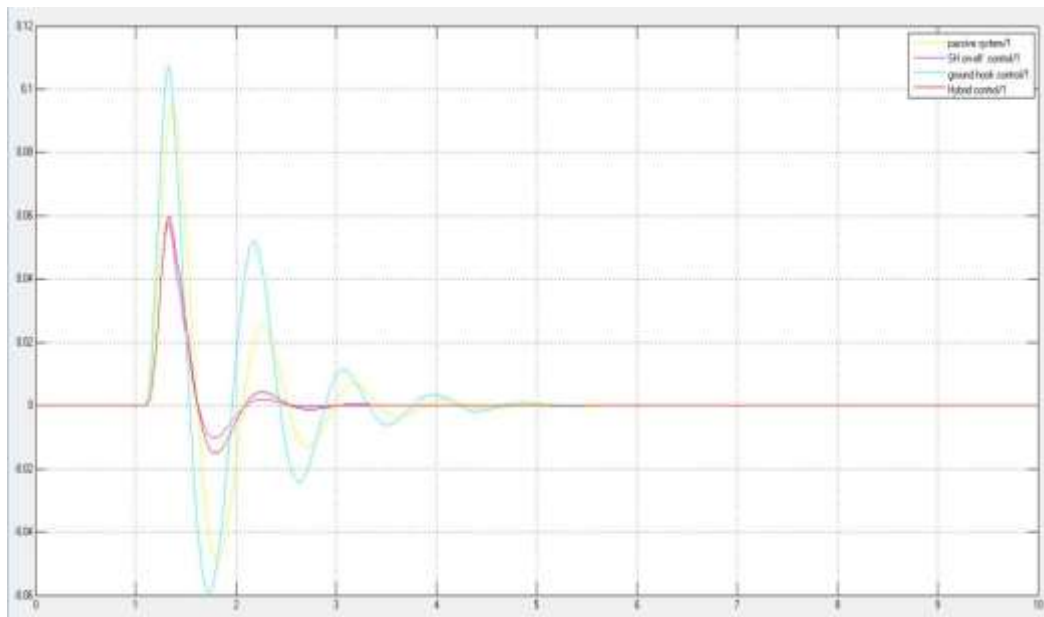

WHEEL VERTICAL DISPLACEMENT

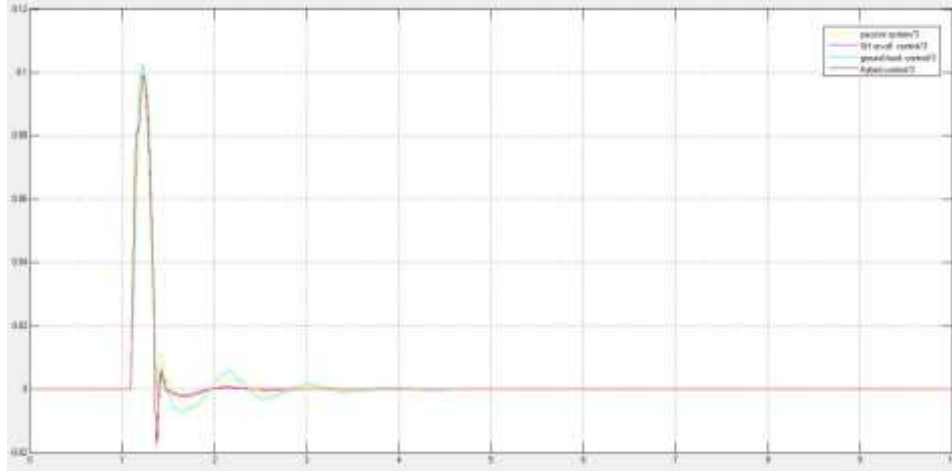

CONCLUSION

1. A control approach based on skyhook on-off, groundhook and hybrid algorithm for semi-active suspension systems has been implemented in the SIMULINK environment. In order to show the effectiveness of the proposed procedure, performance comparison with passive system has been presented in the project.
2. Extensive simulation tests have been performed on a half car model, which provide an accurate enough description of the behaviour of a vehicle equipped with semi-active suspension damping control.

REFERENCES

- [1] Daniel S. Motta, Douglas E. Zampieri and Allah K.A.Pereira, State University of Campinas, "Optimization of a vehicle suspension using a Semi-active Damper", SAE Technical paper 2000-01-3304,2000.
- [2] D. Moline, S. Floyd, S. Vaduri and E. Harry Law, Clemson University, "Simulation and Evaluation of Semi-Active suspensions, SAE Technical paper 940864,1994.
- [3] Mehndi Ahmadian and Fernando D. Goncalves, Virginia Tech, "A frequency analysis of semi-active control methods for vehicle application". SAE Technical paper 2004-01-2098, 2004.
- [4] H.Metered,Helwan University, "Application of Nonparametric magneto rheological damper model in vehicle semi-active suspension system",SAE Technical paper 2012-01-0977,2012,doi:10.4271/2012-01-0977.
- [5] Emmanuel D.Blanchard,"On control aspects of semi-active suspensions for automobile applications", M.sc Thesis, Virginia polytechnic and state University, 2003.
- [6] A.Shamsi and N.Choupani,"Continuous and Discontinuous shock absorber control through skyhook strategy in Semi-active suspension system (4DOF Model), International journal of Aerospace and Mechanical Engineering 2:4, 2008.
- [7] A.Mitra,N.Benerjee and et al, "Simulation and analysis of full car model for various road profile on a analytically validated MATLAB/SIMULINK model", Dept. of Mechanical Engg, National Institute of Technology, NIT Durgapur, India, IOSR Journal of mechanical and civil Engineering (IOSR-JMCE),2278-1684,ISSN(p):2320-334X.
- [8] Shahrir Sarami, "Development and evaluation of a semi-active suspension for full suspension tractors", M.sc Thesis, Technical University-Berlin, 2009.
- [9] Hassen Ahmed Metered, "Modelling and control of MR dampers for vehicle suspension systems",Ph.D Thesis, School of Mechanical, Aerospace and civil Engineering, University of Manchester,2010.
- [10] Sybillah Sulaiman,Pakhrudin mohd Sammin, "Groundhook control of semi-active suspension for heavy vehicle", International journal of research in engineering& Technology (IJRET) Vol-1,no.3.2012,ISSN 2277-4338.
- [11] J.Y. Wong, "Theory of ground vehicles", Carleton University, John Miley & Sons Inc. 3rd edition, ISBN-0-471-35461-9,431-483.